

AGREEMENT

1225 Detroit

Bob Cordes Plbg + Htg, acting as an independent Contractor, does herein guarantee that the work to be done within the right-of-way limits of Detroit St for the construction of new sewer service line

shall be completed in accordance with the specifications as issued by the City of Napoleon Engineering Department. It is further agreed that Bob Cordes Plbg + Htg shall save harmless the City of Napoleon from any liability due to damage of utilities, personal property loss, personal injury, non-payment of suppliers or any possible litigation arising from the construction as stated above.

The City of Napoleon will allow said Contractor to temporarily block off all but local traffic on Detroit from 2-22-94 9:00am to 2-22-94 9: PM for a period not exceeding 12 hours. (The City of Napoleon shall receive 48-hour notice prior to construction.)

As an insurance that the above mentioned work is done according to the Engineer's specifications, a certified check for the amount of \$ 500.00 (made payable to the City of Napoleon) shall be deposited with the Engineering Department and held as surety. If it is the opinion of the Napoleon Engineering Department that the work does not meet specifications, appropriate deductions from the deposit will be made to compensate the City for any corrections necessary. Any portion of the deposit not used by the City of Napoleon for construction corrections will be returned to the contractor 30 days after completion of the work as authorized.

If for any reason the work is not accomplished in the given time, a penalty charge of \$25 for any portion of a day in excess of the allotted time. This penalty charge will be deducted from the monies placed for deposit.

NO WORK WILL BEGIN PRIOR TO OBTAINING THE PROPER TAPPING PERMITS.

The foregoing statement was agreed to on this 22nd day of February, 1994.

Bob Cordes

CONTRACTOR

Terry Quinn

CITY MANAGER
CITY OF NAPOLEON

On February 22, 1994, the above parties appeared before me and indicated their agreement with the contents of this document by their signatures.

Seal:

Sheryl K. Rathge m. Westhoven
Notary Public for the State of Ohio.

My commission expires 10-15-96
SHERYL K. WESTHOVEN
NOTARY PUBLIC, STATE OF OHIO
MY COMMISSION EXPIRES OCTOBER 15, 1996

SEWER TAPPING PERMIT

Issued by

The City of Napoleon Engineering Dept.

255 West Riverview Ave. Napoleon, Ohio 43545 Pn. 592-4010

Entry No. _____

Permit No. _____ Issued 2-21-94 Build. Permit No. _____

Permit Fee \$ 45.00

Job Location 1225 Detroit

Street Bond \$ 500.00

Lot _____

Date Paid _____

Issued By BND sub div. or legal disc.

Owner David Wasserman Pn. 599-7795

Address 1225 Detroit Napoleon

Agent Bob Cordes Pn. 758-3162

Address 17-706 Rd. Q-1 Napoleon

for office use only

WORK INFORMATION

San. Sewer replacement

Sanitary Sewer Tap _____ Size of Tap _____ Size and Type of Sewer _____ Street to be Opened _____

yes no _____ yes no

Storm Sewer Tap _____ Size of Tap _____ Size and Type of Sewer _____ Street to be Opened _____

yes no _____ yes no

Street opening Agreement Approval Date _____ Opening Bond Fee (Set by Engineer) _____

READ AND SIGN BELOW; The undersigned hereby agrees complete the work described above and to make use of said sewers only as allowed by and in strict accordance with all applicable provisions of The Napoleon Engineering Dept. Rules and Regulations, The Napoleon Standard Specification for Water Main, Sanitary Sewer and Storm Sewer Construction and other Pertinent Sections of the Napoleon Code of Ordinances.

Date 2-21-94 Signature of Applicant Bob Cordes

Permit not valid without signature

INSPECTION RECORD _____ to be completed by the Field Inspector

Date Inspection is made _____ Size and Type of Sewer _____

Location _____ Depth _____ Type of Test _____ Additional Information _____

Date _____ Inspected By _____ signature of inspector

Sketch Of Installation on Back or Attached

PAID

FEB 22 1994

CITY OF NAPOLEON

2-23-94 BND

David Wasserman

1225 Detroit

Bob Cordes P.H.

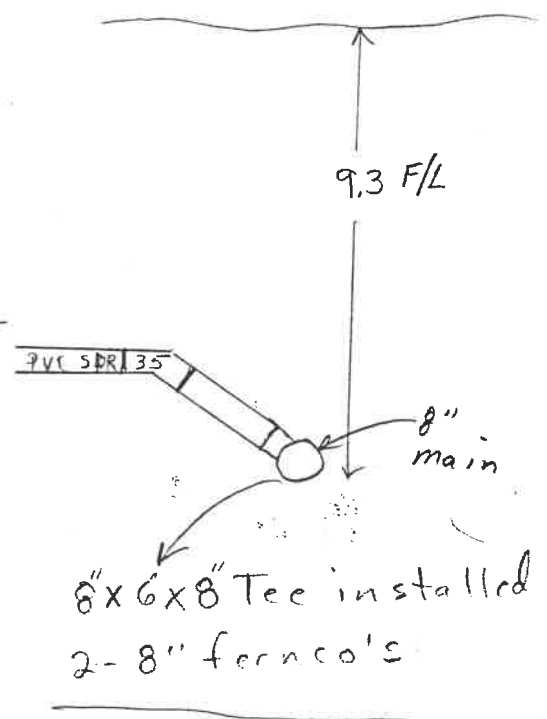
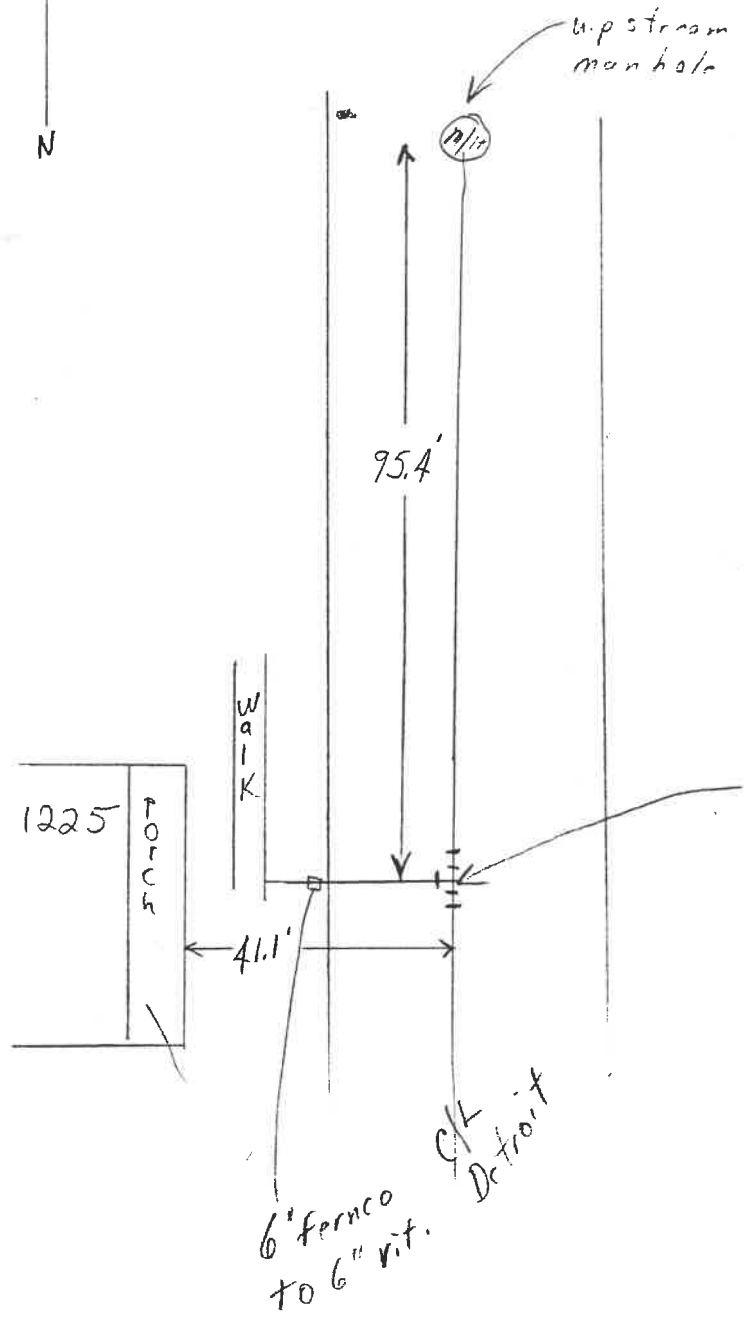

6" ferro
to 6" vit.
C/L
Detroit

8" x 6" x 8" Tee installed
2- 8" ferro's

AGREEMENT

Bob Cordes Plbg + Htg, acting as an independent Contractor, does herein guarantee that the work to be done within the right-of-way limits of Detroit St for the construction of New Sewer service line

shall be completed in accordance with the specifications as issued by the City of Napoleon Engineering Department. It is further agreed that Bob Cordes Plbg + Htg shall save harmless the City of Napoleon from any liability due to damage of utilities, personal property loss, personal injury, non-payment of suppliers or any possible litigation arising from the construction as stated above.

The City of Napoleon will allow said Contractor to temporarily block off all but local traffic on Detroit from 2-22-94 9:00am to 2-22-94 9:00pm for a period not exceeding 12 hours. (The City of Napoleon shall receive 48-hour notice prior to construction.)

As an insurance that the above mentioned work is done according to the Engineer's specifications, a certified check for the amount of \$ 500.00 (made payable to the City of Napoleon) shall be deposited with the Engineering Department and held as surety. If it is the opinion of the Napoleon Engineering Department that the work does not meet specifications, appropriate deductions from the deposit will be made to compensate the City for any corrections necessary. Any portion of the deposit not used by the City of Napoleon for construction corrections will be returned to the contractor 30 days after completion of the work as authorized.

If for any reason the work is not accomplished in the given time, a penalty charge of \$25 for any portion of a day in excess of the allotted time. This penalty charge will be deducted from the monies placed for deposit.

NO WORK WILL BEGIN PRIOR TO OBTAINING THE PROPER TAPPING PERMITS.

The foregoing statement was agreed to on this 22nd day of February, 1994.

Bob Cordes

CONTRACTOR

Terry Quinn

CITY MANAGER
CITY OF NAPOLEON

On February 22, 1994, the above parties appeared before me and indicated their agreement with the contents of this document by their signatures.

Seal:

Sheryl K. Westhoven
Notary Public for the State
of Ohio.
My commission expires 10-15-96
SHERYL K. WESTHOVEN
NOTARY PUBLIC, STATE OF OHIO
MY COMMISSION EXPIRES OCTOBER 15, 1996

